

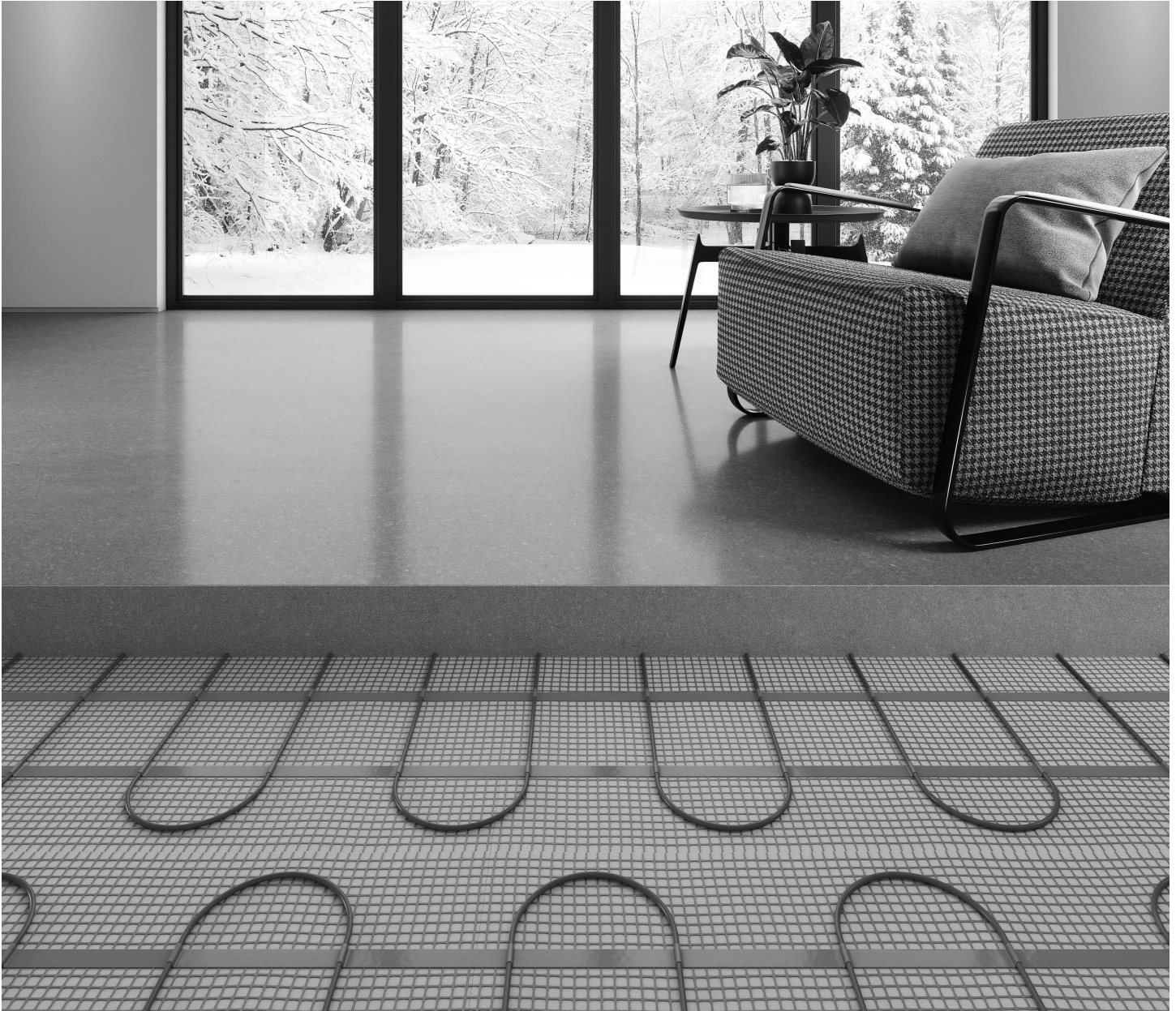

# CONCRETE MAT XPRESS™

## Installation and User Guide

HAND THIS GUIDE TO THE USER AS IT CONTAINS IMPORTANT INFORMATION



INS-TC\_0224

Thank you for your purchase!  
Need help? Contact STELPRO Technical service.

**flextherm.com**  
**elec.tech@stelpro.com**  
**1-844-STELPRO (783-5776)**



HEATING CABLE,  
SERIES TYPE G, W CANADA  
UNCLASSIFIED LOCATIONS USA  
INSTALLATION TYPE C

# 1

## IMPORTANT INSTRUCTIONS

Please read the following manual BEFORE you begin to ensure a proper and safe installation and use of the product.



- This guide contains instructions regarding safety as well as important precautions to ensure a compliant and successful installation. Please pay special attention to this symbol and follow all instructions given.
- This heating system is an electrical appliance and **MUST BE** installed in accordance with this document and regulations of the authority having jurisdiction including the National Electrical Code (NEC), NFPA 70 and CAN/CSA-C22.1, Canadian Electrical Code, Part I (CEC). Its installation must be entrusted to duly qualified personnel where required by law.
- This heating system is designed and approved for Type C indoor floor embedded heating in dry (G) or wet (W) environments in Canada and in unclassified locations in the United States, subject to local electrical standards.
- A permanent Class A GFCI (5 mA) protection is required to protect the cable and the occupants in case of a fault.

# 2

## INTRODUCTION

This installation guide covers the installation of the Concrete Mat Xpress™ (TC series) for residential, commercial, industrial and institutional applications.

The Concrete Mat Xpress™ is made of a self-adhesive mesh on which a 6 W per linear foot heating cable is prefixed at a regular spacing of 15 cm (6 in.) for a surface output of 129 W/m<sup>2</sup> (12 W/ft<sup>2</sup>).

This product is specifically designed to be embedded in concrete slabs or thin-slab toppings and installed on any of these substrates:

CONCRETE MAT XPRESS™ INSTALLATION SUBSTRATES

Substrate	Embedding method	Thickness
Rigid insulation	Concrete slab	Min. 7.6 cm (3 in.)
		Max 15 cm (6 in.)
Plywood or OSB	Topping slab	Min. 4 cm (1.5 in.)
Existing concrete	Topping slab	Min. 4 cm (1.5 in.)



### ON-GROUND MONOLITHIC CONCRETE SLAB

Due to its nature, a monolithic slab exhibits a significantly greater concrete mass at its perimeter. This results in the absorption of a higher amount of heat at the edges, causing a substantial temperature variation compared to the center of the concrete slab. To mitigate these effects, we recommend installing independent perimeter heating mats or cables equipped with their own thermostats.

- Under no circumstances should a heating cable be installed more than 15 cm (6 in.) from the surface of the finished floor.
- In no situation can the spacing be less than 15 cm (6 in.) on-centre.
- Under no circumstances can the power output of the installation be more than 15 W/ft<sup>2</sup>.
- This product can be used as a main source of heating (provided the heat loss of the room falls below the energy installation capabilities) or as an auxiliary heating for the comfort of your feet.
- The ambient and floor temperatures that can be achieved are dependent on the exterior temperature, the insulation of the room including that of the floor's, the window coverage, the flooring used, etc. For more information on how the system can heat the room, refer to a construction professional, an architect or an engineer.

## MATERIALS AND TOOLS

- FLEXTHERM Concrete Mat Xpress kit, including heating cable mat, anchors, floor temperature sensor and Installation and User Guide
- STELPRO thermostat (expansion units available for installation greater than 15 A)
- Two (2) STELPRO conduits for floor temperature sensors (FLS1260T)
- Thermostat connection box and appropriate device cover
- Appropriate multimeter
- Megohmmeter capable of 1000-volt test
- Extruded polystyrene board(s) reinforced with plywood (for cable/mat protection during concrete pour)
- Various tools: measuring tape, marker, calculator, electrical tape, scissors to cut the self-adhesive mesh and latex spray paint or equivalent to mark wall locations, permanent fixtures, movement joints, etc.
- Conduit and fittings\* to run the cold lead from the concrete slab to the thermostat connection box.
- According to the substrate, staples (installation on plywood or OSB), hot glue (installation on concrete; anticipate approximately one glue stick per 25 ft<sup>2</sup>) or adhesive tape.

\*All conduits, fittings, and electrical accessories must be Listed (UL) for the US and Certified (CSA) for Canada

## 3

## COMPATIBLE SUBSTRATES



- The foundation and substrate over which the heating mat will be secured, including any insulation, must be in accordance with the intended usage and the local and/or national codes in effect in your area.

### SUBSTRATE COMPATIBILITIES

Rigid insulation	Plywood	Oriented strand board (OSB)	Smooth concrete	Acoustic membrane
------------------	---------	-----------------------------	-----------------	-------------------

The selected substrate must be clean, flat, smooth and free from any nails, screws, debris or substance that may damage the cables or reduce the bounding properties of the mat.

**NOTE: If a vapour barrier is required, install the Concrete Mat Xpress™ directly on the vapour barrier that has previously been installed on the thermal insulation. The vapour barrier specifications must comply with the applicable local and/or national building codes.**

Check with the substrate manufacturer/association to ensure compatibility with floor heating systems.

#### NOTE ON EXISTING CONCRETE AS A SUBSTRATE

For non-insulated concrete substrate or partial heat mat coverage, STELPRO strongly recommends insulating between the existing concrete slab and the heating mat to limit heat loss.

For the system to heat the floor, the thermal resistance below the heating system should be greater than the thermal resistance above.

#### NOTE ABOUT DIMENSIONAL STABILITY

Floor stability will vary according to the type of flooring installed and its components. Follow tile mortar and self-leveling underlayment manufacturers, Tile Council of North America (TCNA) and Terrazzo Tile and Marble Association of Canada (TTMAC) guidelines to provide movement joints at obstacles and across the room and its perimeter (reference TCNA detail EJ-171 and TTMAC 301MJ).

#### NOTE ON THERMAL RESISTANCE RSI VALUE (R-VALUE)

The maximum allowable thermal resistance of building insulation under heating cable mat is RSI 5.5 (R-31).



- In no case can stapled, nailed or screwed flooring be used over this heating system.
- The flooring installed above this heating system shall cover the entire heated area.

#### FLOORING COMPATIBILITIES

Floor tiles			Soft floor covering*				Wood floors*		
Ceramic	Porcelain	Stone	Vinyl	Linoleum	Carpet	Cork	Floating floor	Engineered wood	Natural hardwood
√	√	√	√	√	√		√	√	

\* Validate the compatibility of the product with the manufacturer.

The poured concrete slab can be used as a traditional subfloor or wear surface or covered with a decorative coating (such as epoxy). Flooring types such as ceramic, porcelain or natural stone are excellent choices for radiant in-floor heating.

Many other flooring types, decorative surfaces or wear toppings are compatible, as long as they are approved for use over heated floors by their manufacturer.

If you choose a floating floor, certain factors could influence heat transmission to the surface such as the thermal resistance of the underlay or the air pockets created by an uneven substrate.

#### FLOORING THERMAL RESISTANCE (RSI/R-VALUE)

The thermal resistance of the flooring installed above this heating system shall be less or equal to RSI 0.18 (R-1).

The table below outlines common thermal resistance values per flooring thickness.

MATERIAL	RSI/R
Concrete 1" (25 mm)	RSI 0.01 / R-0.06
Vinyl 1/8" (3 mm)*	RSI 0.04 / R-0.20
Ceramic 3/8" (10 mm)	RSI 0.06 / R-0.34
Engineered wood 1/2" (13 mm)*	RSI 0.09 / R-0.50
Floating floor 3/8" (10 mm)*	RSI 0.09 / R-0.50
Carpet without rubber backing 3/8" (10 mm)*	RSI 0.18 / R-1.00

\* Check the flooring's actual RSI/R value with the manufacturer.



WARNING!

- Make sure the circuit dedicated to the heating cable is of the same voltage as the cable specification. Never connect a cable designed for 208/240 volts on a 120-volt circuit.

### CIRCUIT

Floor heating systems must be connected to electrical circuits dedicated to heating. The heating power (Watts) of the cable, as indicated on the cold lead label, will determine the required circuit intensity (Amps). Please take note that the maximum load that can be connected to a STELPRO thermostat is 15 A.

For a load greater than 15 A, it must be distributed to an expansion unit, a relay or an additional thermostat. For further information regarding their connection please refer to the literature included with those products.

### CONNECTION BOX

Determine the thermostat (and expansion units if needed) location.

- The thermostat should be in an accessible location in the room where the system will be installed and at an appropriate height.
- The expansion unit(s) might be located elsewhere but must remain accessible.
- Use expanded connection boxes such as a 4 in. x 4 in. box, with conduit knockout holes and appropriate device cover.

### CONDUIT

1. Install an elbow-shaped conduit to transition the cold lead from the concrete slab to the wall where the control unit will be installed.
2. If needed, secure the elbow with tie wraps to a steel rod driven into the ground. For more information, refer to your local electrical code.

**According to the electrical code of your region, it might be necessary to extend the conduit up to the thermostat's junction box.**



## HEATING CABLE MAT AND FLOOR TEMPERATURE SENSORS CHECK



**WARNING!**

- Never connect a cable while the mat is still rolled up. To test the cable, use the following procedure.
- Before removing the seal (orange tie), the cable insulation and its resistance must be verified to validate the cable conformity. A heating cable mat whose seal has been broken cannot be returned.

### HEATING CABLE RESISTANCE VERIFICATION

Use an appropriate multimeter to measure the resistance between the black lead wires. The resistance value of the cable is indicated on the label attached to the end of the cold lead.

The test result should be  $\pm 10\%$  the resistance indicated on the label.

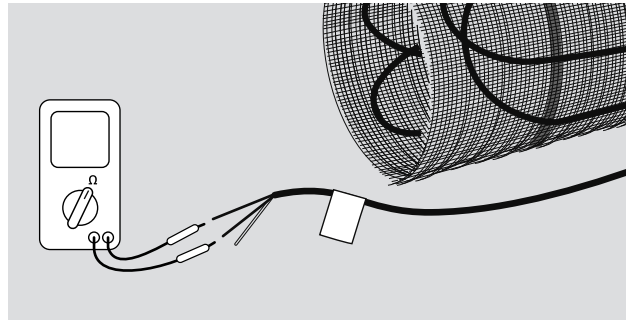

### HEATING CABLE INSULATION VERIFICATION

Use a megohmmeter to check the cable's insulation integrity. Set the test voltage at 1000 V and apply tension between the green wire and one of the black lead wires for at least six (6) seconds.

The test result should be infinite resistance (I, OL). Record the results in the Test Log.

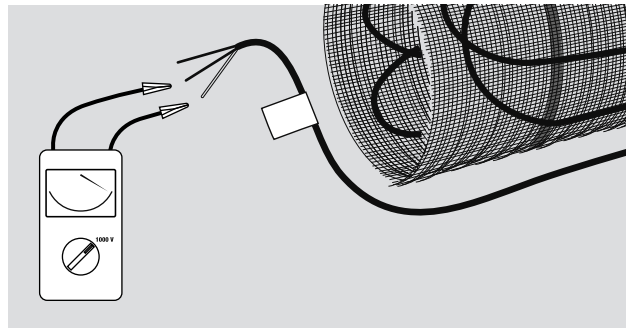

### FLOOR TEMPERATURE SENSORS RESISTANCE CHECK

Two (2) floor temperature sensors are available for your system installation. One is included with the heating cable mat, and the other with the thermostat. It is recommended to install both sensors on the floor in different locations as a backup in case one of them fails or does not give satisfactory results.

Each time you test the cable's integrity, measure the resistance of the floor temperature sensor(s) between the two wires and report the results in the Test Log.

If the measured values do not correlate with the table, call STELPRO Technical service.

AMBIENT TEMPERATURE	OHM ( $\Omega$ ) +/- 10%	KOHM ( $\Omega$ ) +/- 10%
5°C (41°F)	22,200	22.2
10°C (50°F)	18,400	18.4
15°C (59°F)	14,800	14.8
20°C (68°F)	12,400	12.4
25°C (77°F)	10,100	10.1
30°C (86°F)	8,400	8.4

Check the cable two more times as a system integrity control measure: once the mat is secured to the substrate and after the mat has been embedded in the concrete pour. Report all test results in the Test Log included in this installation guide.

If the results obtained in any of the tests do not comply with the labeled cable specifications, contact STELPRO Technical service.



- Accurate measurements are the key to a successful installation. Verify your measurements to ensure that you have the proper mat length for the project. A measurement guide is available on FLEXTHERM's website.

## GENERAL INSTRUCTIONS

Before the installation:

- The heating cable must be installed at a minimum distance of:
  - 5 cm (2 in.) from fixed furniture, cabinets (toe kick), patio doors, bath or shower steps.
  - 5 cm (2 in.) from walls.
  - 10 cm (4 in.) from non-heating conduits such as tubes, pipes or vents.
  - 15 cm (6 in.) from the centre of toilet drains and 5 cm (2 in.) from toilet bases.
  - 20 cm (8 in.) from receptacles, switches and electrical outlets.
  - 20 cm (8 in.) from heating devices.
  - 20 cm (8 in.) from heating tubes, pipes, vents or ducts.
- Each enclosed area where a floor heating system is installed must have a thermostat to control the temperature.
- The heating cable may extend to adjacent rooms and be controlled by a single thermostat.
- The heating cable cannot be crossed, cut, shortened or modified.
- The mat runs must be adjacent to each other.
- The mat/cable must be embedded in concrete at a minimum depth of 4 cm (1.5 in.) and a maximum depth of 15 cm (6 in.) from the surface of the slab.
- The only authorized anchoring devices for the heating cable of the Concrete Mat Xpress™ are the supplied anchors or staples especially manufactured to avoid damages to the cable.
- The floor temperature sensors and the entire heating portion of the cable, including the mechanical joint and heating cable end, must be secured to the substrate and covered with concrete.
- The heating cable must never be installed under, in or over walls or partitions.
- The system must not be installed under fixed furniture or where air does not flow freely.
- The system should never be installed in closets (USA only).
- Avoid installing heating cables in a closet where objects may trap heat to the floor (Canada only).
- The heating cable must never cross a movement joint such as an expansion or control joint.
- The minimum bending radius of the heating cable is 4.5 cm (1-3/4 in.).
- The system should not be installed in conditions below 0°C (32°F) ambient air temperature.
- To maintain a uniform floor temperature, ensure that the entire area controlled by the heating cable thermostat is covered with the same type of flooring.
- Despite what was mentioned earlier, it is possible to install a short section of heating cable, less than 2 feet in length, on a vertical surface such as a stair step. It is imperative that the cable be encapsulated with a minimum of 5 cm (2 in) of cement and protected against any penetration. When transitioning from one surface to another, it is necessary to adhere to the minimum bending radius by transferring the cable diagonally between the planes. It is important to note that such applications must be approved by the relevant inspector in your area.





## SECURING THE HEATING MAT TO THE SUBSTRATE

The Concrete Mat Xpress™ is built with a self-adhesive mesh that will facilitate its installation.

1. Break the mat seal (orange tie). Based on your installation plan, run your floor heating mat in the lengths required, cutting the mesh (careful not to cut/damage the heating cable) in the appropriate locations.
2. Apply light pressure on the self-adhesive mesh to ensure adhesion of the mat to the substrate. Avoid making any warping, waving or ripples with the mat.

### Installation on rigid insulation

1. Secure the mat with the anchors provided every 30 cm (1 ft.) while alternating sides.

**NOTE: the plastic anchors are designed to perfectly fit around the heating cable.**

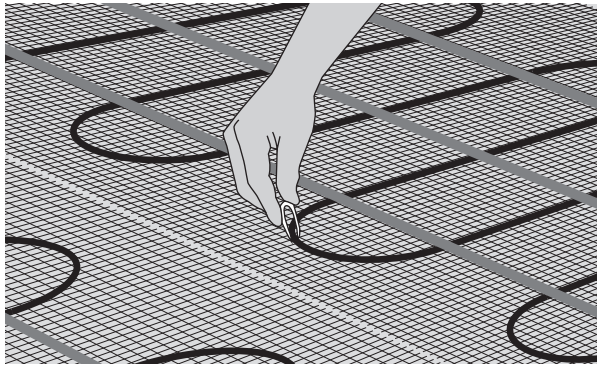

### Installation on plywood or OBS

1. Staple the mat.

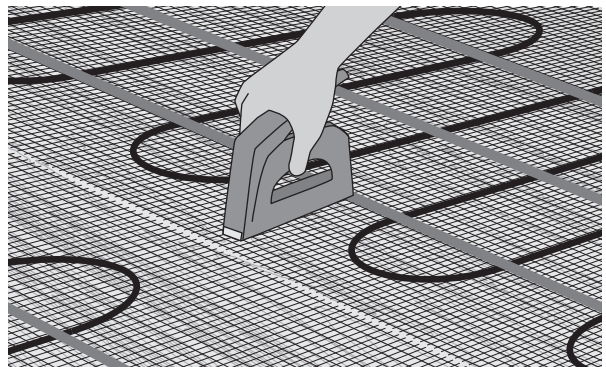

### Installation on concrete

1. Use hot glue on or tape the edges of the mat.



• Make sure not to touch the cable with the tip of the hot glue gun

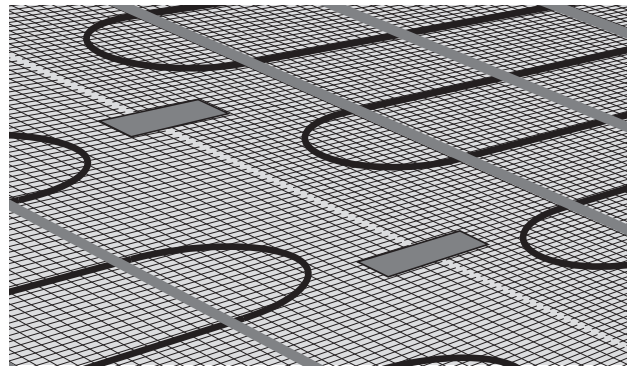
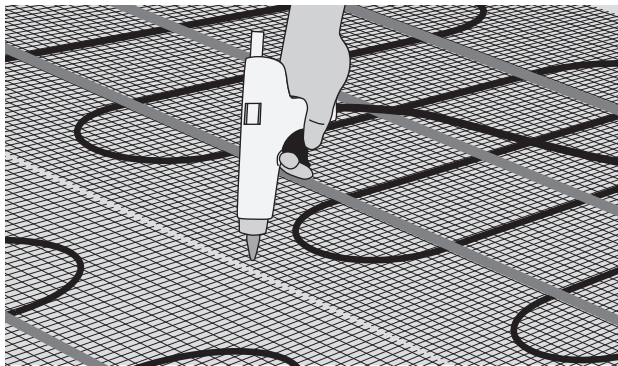

When handling the mat to go around certain objects, it may sometimes be necessary to install it on its non-adhesive side. In such situations, secure the mat using the methods outlined above.

### TURNING 90°

1. Free one cable run from the mat.
2. On rigid insulation, install the freed part of the cable [A] using the provided anchors. For installation on another substrate, secure the cable using hot glue or use released strips of mesh as fasteners for the cable by applying them to the cable and securing the strips to the substrate with staples or adhesive tape.
3. Make sure the 15 cm (6 in.) spacing between cables is observed in all directions.
4. A small cold spot [B] will result from this operation. Make sure it is by the wall or in a low traffic area.

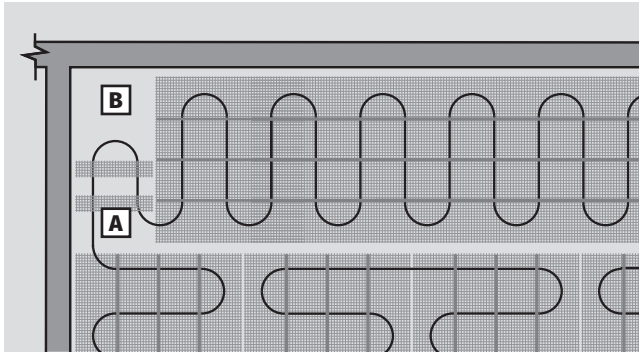

### TURNING 180°

1. Cut the self-adhesive mesh from one side to the other.
2. Turn the roll 180° and unroll in the opposite direction, making sure to align the edges of the mat.

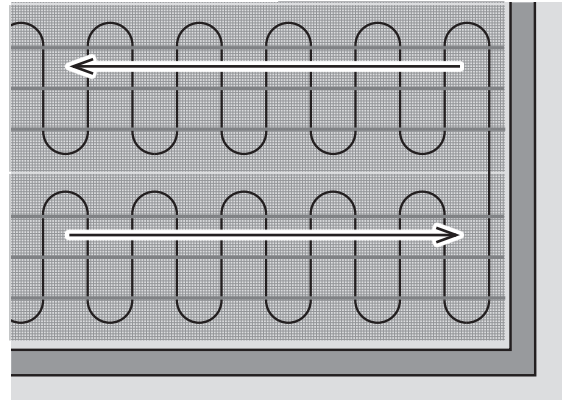

### SKIRTING AROUND OBSTACLES

1. Free the required length of cable from the mesh with a pair of scissors.
2. On rigid insulation, install the freed part of the cable [A] using the provided anchors. For installation on another substrate, secure the cable using hot glue or use released strips of mesh as fasteners for the cable by applying them to the cable and securing the strips to the substrate with staples or adhesive tape.
3. Maintain the 15 cm (6 in.) spacing between cable runs.

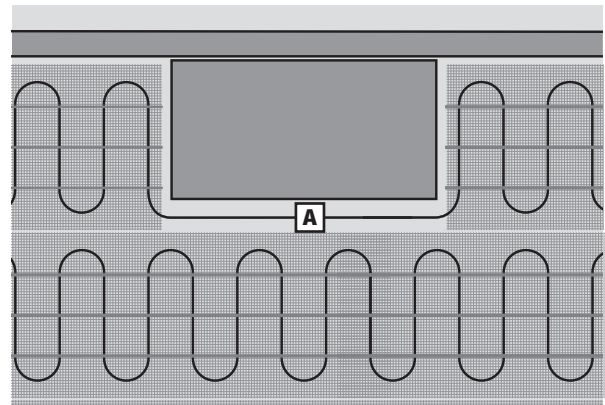

### MECHANICAL JOINT INSTALLATION AND COLD LEAD PREPARATION

1. To maintain the identification label [A] in place, wrap and tape the label around the cold lead before fishing the cold lead in the conduit.
2. Pull the cold lead through the elbow-shaped conduit and temporarily secure it away from the upcoming work.
3. Ensure the mechanical joint is firmly secured to the installation surface, in the zone where concrete will be poured and outside the conduit.

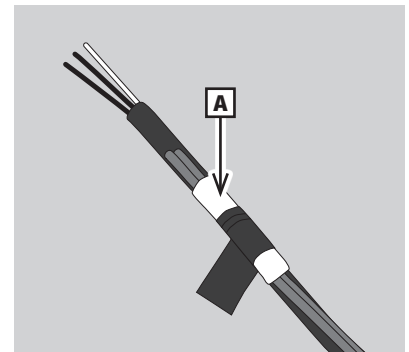

WARNING!

- The cable identification label must remain on the cold lead cable. Removing it will void the cable's limited warranty.

## FLOOR TEMPERATURE SENSORS INSTALLATION

The floor temperature sensor conduits (FLS1260T) must run from the future concrete slab up to the thermostat connection box.

1. Insert the floor temperature sensor up to the end of its conduit and cap the end with the plug supplied.
2. Secure the floor temperature sensor cable to the conduit with electrical tape to prevent it from moving.
3. When embedding the system in a concrete slab, secure the end of the conduit to a support (e. g., rigid insulation block, brick or concrete block) placed between two cable runs in order to raise the sensor at a distance of 5 cm (2 in.) from the floor finish, without crossing a heating cable.
4. Make sure the support and conduit are well secured to the ground, so they stay in place when the concrete is poured.
5. If installing the system on plywood, OSB or existing concrete with a thin topping slab, the floor temperature sensor conduit can be installed directly on the subfloor between cable runs without crossing them.
6. Repeat the previous steps to install the second floor temperature sensor in a different location.

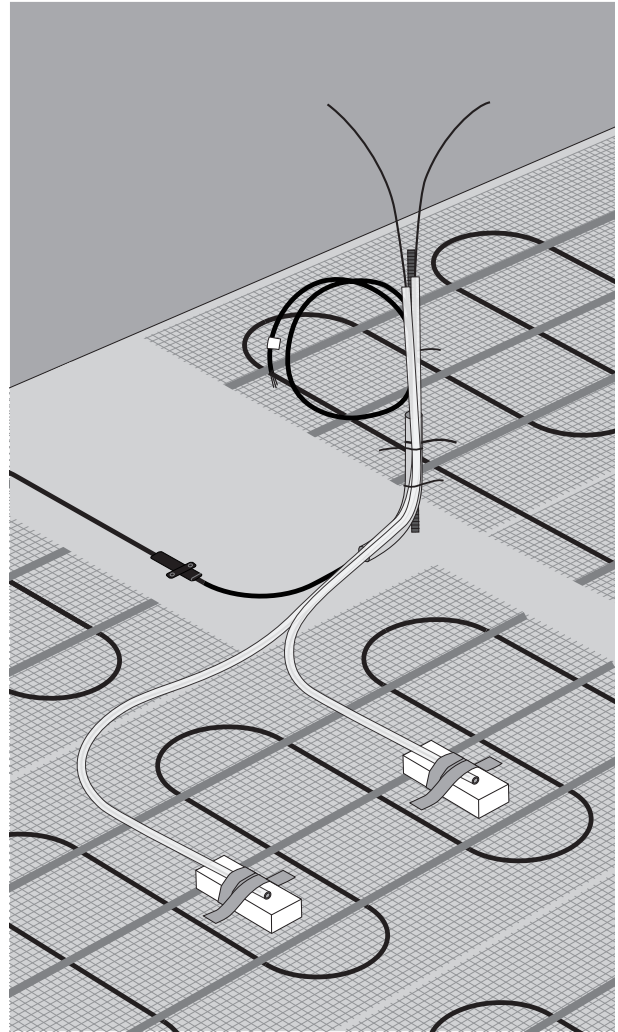

WARNING!

- The sensors should be installed in the center of a heated floor diameter of at least 60 cm (24 in.). The sensors should be placed in a representative area of the usual floor temperature, 2 in. from the flooring, far from any other heating or cooling sources or potential objects preventing the air to flow freely on the floor.

## 8

## HEATING CABLE MAT AND FLOOR TEMPERATURE SENSORS CHECK AFTER INSTALLATION

Once the mat installation is completed, check cable and floor temperature sensor integrity as described in the “HEATING CABLE MAT AND FLOOR TEMPERATURE SENSORS CHECK” section on page 6. Record the results in the Test Log.

Do not pour the concrete if the cable is damaged during installation. Contact STELPRO Technical service.



WARNING!

- **PROTECT THE CABLE:** Reduce to a minimum the time between the cable installation and the concrete pour. Protect the cable with cardboard or similar soft material and restrict access to the area. A hard material (such as a plywood sheet) could damage the cable.
- **DOCUMENT YOUR MAT INSTALLATION:** Take photographs of the installation before the mat is covered. These pictures should show that your installation meets all the standards and written instructions and will be a useful reminder for future renovations.

## 9

## SAFE PRACTICES DURING THE CONCRETE POUR

Some precautions must be taken to prevent cable damage when pouring concrete:

- Be careful with the cable when walking on the mat.
- Use extruded polystyrene boards affixed to plywood sheets (plywood side up) laid down over the cables to prevent damage.
- Even though it's possible to use a wheelbarrow to pour the concrete, STELPRO recommends the use of a concrete pump.
- Make sure to install the aforementioned protection **[A]** before placing the concrete pump hose couplings on the ground or when transporting concrete with a wheelbarrow.
- When a metallic wire mesh is installed to reinforce the slab, install chairs or bricks between cable runs to keep the wire mesh away from the heating cable.
- When pouring the concrete, always lift the end of the pipe so that it does not touch the heating cable.
- Always use smooth scrapers to spread the concrete. Ensure the scraper does not get caught in the cables during this operation.
- If needed, vibrate the concrete with care to prevent any damage to the cables.

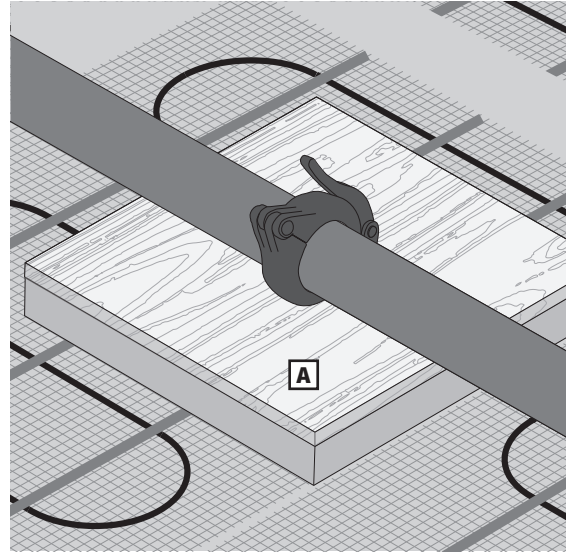

## 10

## HEATING CABLE MAT AND FLOOR TEMPERATURE SENSORS CHECK AFTER CONCRETE POUR

Once the concrete pour is completed, verify cable and floor temperature sensor integrity as described in the section “HEATING CABLE MAT AND FLOOR TEMPERATURE SENSORS CHECK” section on page 6. Record the results in the Test Log.

Do not install the flooring if the cable is damaged during the concrete pour. Contact STELPRO Technical service.

## 11

## CURING PERIOD



WARNING!

- Do not turn the system on immediately after the concrete is poured. The system can be operated only after the concrete has completely cured.
- Refer to construction professional or local building code guidelines to verify the curing time: this curing period is essential for the concrete to reach its full strength.

## 12

## FLOORING INSTALLATION (OPTIONAL)

Install the floor covering in accordance with the manufacturer's recommendations.



WARNING!

- Never screw or nail into the floor.
- The heating system will perform better if the flooring is in direct contact with the concrete slab surface; avoid air gaps.



- A permanent Class A GFCI (5 mA) protection is required to protect the cable and the occupants in case of a fault.
- Use STELPRO thermostats to operate the floor heating cable. These thermostats are designed to operate radiant floors and are equipped with a built-in Class A (5 mA) Ground Fault Circuit Interrupter (GFCI).
- **RISK OF ELECTRIC SHOCK AND FIRE.** Turn off the power of the designated electrical circuit prior to connecting the system control units.
- The circuit(s) supplying the heating system must be clearly marked and referenced with the supplied label at the electrical panel.

1. Connect the green ground wire from the system to the terminal in the junction box.
2. For instructions on how to connect the heating cable to the thermostat, refer to the thermostat installation guide.
3. Connect a single floor temperature sensor cable to the thermostat, while leaving the second sensor cable inside the electrical box for future purposes.



- Do not turn the system on immediately. The system can be operated only after the concrete, tile mortar and/or self-levelling underlayment has completely cured. This waiting period is essential to ensure that the cementitious material is properly set.
- Refer to the manufacturer's instructions to comply with the required curing time of the product (between 7 and 28 days).

#### CURING PERIOD

Before starting the system, respect the appropriate curing period. Refer to the preceding section (System Start-up).

#### AREA RUGS, FURNITURE AND CLOSETS

Do not lay down a rug on a floor equipped with a heating system. The heat that would be trapped could damage your rug, the flooring or the heating cable. The use of a bathmat is acceptable as long as it is taken off the floor once the bath period is over.

Do not lay down on the floor permanent furniture or large objects under which air does not flow freely.

Avoid placing objects trapping heat on the heated floor of a closet.

#### FLOOR TEMPERATURE LIMITATION

Be aware that floor coverings other than ceramic, porcelain and stone may have temperature limitations by their manufacturer. Use the floor temperature limit feature of the thermostat.

#### FLOOR PENETRATION

Any renovation and/or modification to the floor may damage the cable if proper care is not taken. Floor penetration with nails, screws or similar devices is prohibited.

#### FLOORING REPAIR

Should the flooring need repair, proceed with caution. Turn off

the power supply to the heating system and carefully remove the piece of flooring that needs to be repaired without damaging the heating cable.

#### CABLE REPAIR

Should the cable be damaged and/or the thermostat GFCI be activated, the system must be deactivated and must not be operated. Turn off the power supply to the heating system. THE CABLE CAN BE REPAIRED. A repair kit (product code: FSK-05) is available from your FLEXTHERM dealer.

Never attempt to repair a cable located in a wet area; contact STELPRO Technical service.

Do not use a heated floor if a section of the floor covering is missing.

#### MAINTENANCE

FLEXTHERM's Floor Warming and Heating System is maintenance free.

#### TROUBLESHOOTING

Should you experience any problems with your floor heating system, first call your installer. If you cannot get satisfactory results, call STELPRO Technical service from 8 a.m. to 5 p.m. EST at 1-844-STELPRO (783-5776); make sure you have the thermostat and cable model number(s) and all test results from the Test Log.



- **The Test Log must be COMPLETED and RETURNED to STELPRO to activate the warranty, failing which: THE WARRANTY WILL NOT BE ACTIVATED AND, CONSEQUENTLY, WILL NOT BE VALID. All required information and test results must be entered in the Test Log, as indicated in this guide.**

STELPRO Design Inc. (hereinafter “STELPRO”) warrants to the original purchaser that the floor heating mat (hereinafter the “Product”) as designed and manufactured by STELPRO, and once installed in conformity with the instructions of STELPRO, shall be free of defects, in either materials or workmanship as described in this document.

#### COVERAGE PERIOD

This limited warranty becomes effective on the date of purchase of the Product by the first owner and shall remain effective for a period of twenty (20) years [two hundred forty (240) consecutive months] from the date of original purchase of the mat. This limited warranty is valid for Products bought and installed in Canada and the United States only.

#### LIMITED LIFETIME WARRANTY

For the Limited Lifetime Warranty to apply, the product must be installed by a FLEXpert or FLEXboutik through an installer certified by STELPRO, and a completed Test Log must be submitted and must include all the results of the insulation and resistance verification tests carried out before breaking the security seal, after the installation of the mat, and after the concrete pour.

#### CONDITIONS

This limited warranty is only applicable to new and unused products purchased from STELPRO, or its authorised re-sellers, provided the installation requirements contained in the product installation guide are met. Claims made for coverage under this limited warranty must be addressed in writing, within seventy-two (72) hours from an event giving rise to a claim, or the appearance of a defect, to STELPRO Inc.

Email: [elec.tech@stelpro.com](mailto:elec.tech@stelpro.com), or

Mail: **STELPRO Technical service, 1041, rue Parent, Saint-Bruno-de-Montarville, (Québec) J3V 6L7 Canada.**

Persons making claims for coverage must present STELPRO with proof of purchase as well as proof of installation in accordance with the installation requirements (pictures recommended), the completed Test Log and any documents STELPRO may require.

Any parts replaced under the terms of this limited warranty become the property of STELPRO.

#### WHAT STELPRO WILL/WILL NOT DO

STELPRO’s obligations under this limited warranty are limited to, at its sole discretion, repairing or reimbursing the mat originally supplied in the Product that STELPRO has determined to be defective in materials or workmanship.

STELPRO shall repair or reimburse, at its sole and entire discretion, the defective cables goods free of charge. Repair or replacement will only be made for defective parts; and no allowance or reimbursement shall be made for wages, labour and freight costs. Should STELPRO chose to reimburse the cost of the mat, it will do so at the lesser of the value of the purchase price or the suggested retail price for the same item. With respect to the parts not manufactured by ourselves, we shall only warrant for these to the same extent as our suppliers undertake a warranty obligation towards ourselves.

Because of our ongoing commitment to product quality and innovation, STELPRO reserves the rights, at any time and without incurring any obligations, to revise, change, modify or discontinue any specifications, features, designs or components.

#### INSTALLATION REQUIREMENTS

In addition to the requirements included in the current STELPRO Installation Guide, which is incorporated herein by this reference, the Product must be installed in accordance with accepted standards, with STELPRO thermostats (or a suitable equivalent, as determined by STELPRO) and with adhesives that are compatible with an electrical floor heating system.

- **WARNING:** Failure to install the Product with controls and protection systems (including ground fault circuit interrupters) in conformity with your local electrical codes, as well as indicated in the installation guide, may cause fires.

#### WARRANTY EXCLUSIONS

- Failures resulting from improper installation.
- Damage caused by abuse, improper installation, repairs, service, maintenance and/or storage, modifications or use of parts not manufactured or supplied by STELPRO.
- Damage caused by abuse or neglect of the Product.
- Use of thermostats other than STELPRO thermostats or suitable equivalents.
- Damage caused by water, submersion, accident, fire or any act of God.
- Incidental, consequential or other damages (including labour costs, inconvenience, loss of time or loss of income).

#### LIMITATION OF LIABILITY

THIS WARRANTY IS EXPRESSLY GIVEN AND ACCEPTED IN LIEU OF ANY AND ALL OTHER WARRANTIES, EXPRESSED OR IMPLIED, INCLUDING WITHOUT ANY LIMITATION ANY WARRANTY OF MERCHANTABILITY OR FITNESS OR A PARTICULAR PURPOSE. TO THE EXTENT THAT THEY CANNOT BE DISCLAIMED, THE IMPLIED WARRANTIES ARE LIMITED IN DURATION TO THE LIFE OF THE EXPRESSED LIMITED WARRANTY. INCIDENTAL AND CONSEQUENTIAL DAMAGES ARE EXCLUDED FROM COVERAGE UNDER THIS LIMITED WARRANTY. SOME STATES AND PROVINCES DO NOT ALLOW FOR THE DISCLAIMERS, LIMITATIONS AND EXCLUSIONS IDENTIFIED ABOVE; AS A RESULT, THEY MAY NOT APPLY TO YOU. THIS WARRANTY GIVES YOU SPECIFIC RIGHTS WHICH MAY VARY FROM ONE STATE OR PROVINCE TO ANOTHER.

Neither STELPRO products re-sellers, installers or any other person is entitled or authorized to make any affirmation, representation or warranty other than those contained in this limited warranty.



# CONCRETE MAT XPRESS™

## Test Log

### PRODUCT INFORMATION (SEE IDENTIFICATION LABEL)

Model number	
Length	
Resistance (Ω)	
Voltage (V)	
Rated output (W)	
Production number	

#### Example

TC120K0191	MODEL NO.
58.2 m (191 ft/pi)	LENGTH
58 Ω	RESISTANCE
120 V	VOLTAGE
645 W	RATED OUTPUT
203192401461	PRODUCTION NO.

Commissioning date (yyyy/mm/dd)

Purchase date (yyyy/mm/dd)

Room

New construction

Renovation

### CONSUMER

First name

Last name

Address

Email

Phone number

### RETAILER

Company name

Address

### HEATING CABLE MAT INSTALLER

First name

Last name

Company name

Address

### THERMOSTAT INSTALLER

First name

Last name

Company name

Address



**CONCRETE  
MAT XPRESS™**

**Test Log**

The Test Log must be COMPLETED and RETURNED to Stelpro to activate the warranty, failing which:  
THE WARRANTY WILL NOT BE ACTIVATED AND, CONSEQUENTLY, WILL NOT BE VALID.  
All required information and test results must be entered in the Test Log, as indicated in this guide.

	FACTORY SETTINGS	BEFORE BREAKING THE SECURITY SEAL	AFTER INSTALLATION	AFTER CONCRETE POUR
DATE YEAR: MONTH: DAY:				
HEATING CABLE RESISTANCE ( $\Omega$ )				
INSULATION RESISTANCE ( $M\Omega$ )	INFINITE			
FLOOR TEMPERATURE SENSOR #1 RESISTANCE ( $K\Omega$ )	10: $K\Omega$ @ $25^{\circ}C / 77^{\circ}F$			
FLOOR TEMPERATURE SENSOR #2 RESISTANCE ( $K\Omega$ )	10: $K\Omega$ @ $25^{\circ}C / 77^{\circ}F$			
INSPECTOR'S NAME				

Keep a copy of this Test Log and email a copy to: [elec.tech@stelpro.com](mailto:elec.tech@stelpro.com)  
or mail a copy to: **STELPRO Technical service, 1041, rue Parent, Saint-Bruno-de-Montarville, (Québec) J3V 6L7 Canada**  
To make a warranty claim, submit this Test Log along with the purchase invoice.